

Modeling of the Safety Climate and the Cultural Attitudes to Predict Unsafe Behaviors Using the Neuro-Fuzzy Inference System (ANFIS)

Reza Pourbabaki¹, Zahra Beigzadeh¹, Behnam Haghshenas², Ali Karimi^{3*}, Zahra Alaei¹, Saeid Yazdanirad⁴

¹MSc, Department of Occupational Health Engineering, School of health, Tehran University of medical sciences, Tehran, Iran • ²MSc, Department of Occupational Health Engineering, School of health, Esfahan University of medical sciences, Esfahan, Iran • ³Associate Professor, Department of Occupational Health Engineering, School of health, Tehran University of medical sciences, Tehran, Iran • ⁴PhD student, Department of Occupational Health Engineering, School of health, Tehran University of medical sciences, Tehran, Iran • *Corresponding Author: Ali Karimi, Email: a_karimi@sina.tums.ac.ir, Tel: +98-21-55951390

Abstract

Background: Unsafe behavior in industries can be due to different factors. The aim of this study was to predict and model unsafe behavior using a safety atmosphere and cultural attitudes questionnaires. **Methods:** This study was a descriptive-analytic and cross-sectional examination that analyzed the data and predicted the unsafe behaviors of 90 construction workers using Neuro-Fuzzy Inference System (ANFIS) in MATLAB R2016a software. **Results:** In this study, the model of the safety atmosphere - unsafe behavior and the model of the cultural attitudes - unsafe behavior had the regression coefficients of 0.93373 and 0.9234, respectively. It showed that each of the parameters has a close relationship to the rate of the unsafe behavior. In this regard, a combination of the safety atmosphere and safety attitude parameters for the estimation of the unsafe behaviors achieved the better results with a regression coefficient of 0.9453 which indicates the direct effect of both parameters simultaneously on unsafe behavior. **Conclusion:** Based on the findings, it can be concluded that the neuro-fuzzy model can be used as an appropriate tool for predicting unsafe behavior in the industries.

Keywords: Unsafe behavior; Cultural attitude; Safety atmosphere; Prediction; Neuro-fuzzy inference system

Introduction

The construction industry is considered as one of those industries facing safety challenges.¹ Studies in different countries including Iran had shown that the adverse effects and consequences of safety in the construction industry are high.²⁻⁴ Due to the great importance of accident control; different researches and models have been carried out regarding the causes of accidents so far. Most of which highlighted two key factors in the presence of unsafe behavior and unsafe conditions as the most important causes of accidents. Therefore,

identifying unsafe behavior can help developing corrective and strategic measures.^{5, 6} Safety and cultural attitudes are among the factors that can influence workers' unsafe behavior.^{7, 8} The safety atmosphere is a state of safety that represents the basis of a safety culture in workgroups, factories, or organizations and is known as a useful tool for measuring employees' behavior and attitudes toward safety.^{9, 10} Many dimensions are known as parts of a safe atmosphere. These include managerial values, organizational and management activities, communication, and the employee's

Citation: Pourbabaki R, Beigzadeh Z, Haghshenas B, Karimi A, Alaei Z, Yazdanirad S. **Modeling of the Safety Climate and the Cultural Attitudes to Predict Unsafe Behaviors Using the Neuro-Fuzzy Inference System (ANFIS).** Archives of Occupational Health. 2020; 4(2): 548-56.

Article History: Received: 14 January 2019; Revised: 6 March 2019; Accepted: 15 April 2019

Copyright: ©2020 The Author(s); Published by Shahid Sadoughi University of Medical Sciences. This is an open-access article distributed under the terms of the Creative Commons Attribution License (<https://creativecommons.org/licenses/by/4.0/>), which permits unrestricted use, distribution, and reproduction in any medium, provided the original work is properly cited.

participation in safety and health programs.^{11, 12} Studies have shown that by using a validated safety atmosphere questionnaire, one can address the safety status of industries.^{7, 8}

One of the first and foremost studies of cultural attitudes to Hofstede's theory is the Dutch researcher conducted in 1980 which has four dimensions (the index of masculinity-feminism, the index of collectivism-individualism, the ambiguity index, and the power gap index). It defines the dimensions of culture. These four dimensions express the main characteristics of the social values mentioned.¹³ Studies have shown that using a cultural attitude questionnaire can be an effective method for assessing safety performance.¹⁴⁻¹⁶ In recent years, researchers have attempted to analyze and describe different types of models for the cause of events.¹⁷⁻¹⁹ Given that prediction methods are mainly quantitative; quantitative estimation of a parameter is difficult, so most accident analysis methods rely on qualitative methods.²⁰ The following describes the theory of fuzzy methods and artificial neural network algorithm for further details.

Fuzzy systems

The ability of fuzzy systems to solve complex problems of modeling and prediction, control and artificial intelligence has also been confirmed.²¹ A fuzzy inference system consists of three major parts. 1. The fuzzification step at the input that converts the numeric value of the variables into a fuzzy set. 2. Fuzzy inference engine that converts inputs into outputs with a series of actions. 3. A diagram that converts the phase output to a definite number as shown in Figure 1.²²

Artificial neural network

The neural network is a promising new technology used to study complex and multidimensional phenomena.²³ From a neural network perspective, it has been tried to model how the nervous system and the human brain function.²⁴ This approach can solve complex problems by relying on learning and parallel processing capability in natural neural networks.²⁵ Figure 2 is an example of a neural network.^{21, 26}

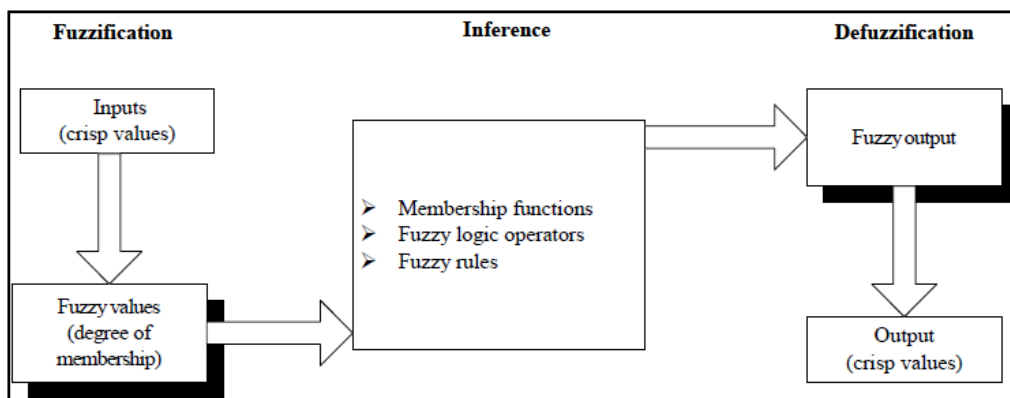

Figure 1. A Fuzzy Inference System

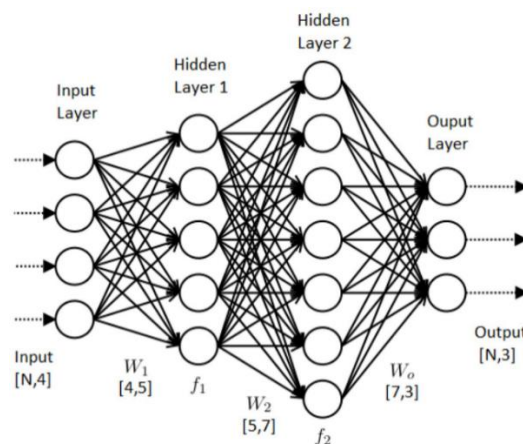

Figure 2. Neural network schematic diagram

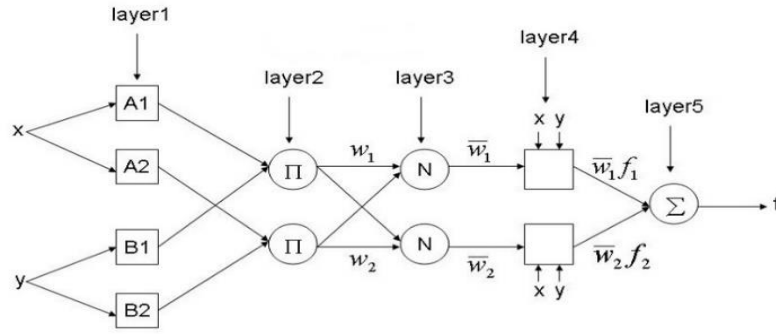

Figure 3. ANFIS architecture

Adaptive Neuro-Fuzzy Inference System (ANFIS (Adaptive Neuro-Fuzzy Inference System))

The idea of combining fuzzy logic and neural network for modeling was first used by Athanassopoulos and Curram for classification and prediction.²⁷ In order to simplify, it is assumed that the inductive system of interest has two inputs of x and y and one z output. For a Takagi-Sugeno model, firstly, one can set a set of sample rules with two if-then fuzzy expressions as follows:

Rule 1: If x is equal to A1 and y is B1, then z1 = p1x + q1y + r1

Rule 2: If x is equal to A2 and y is equal to B2, then z2 = p2x + q2y + r2

Where pi, qi, and ri (i = 1, 2) are linear parameters in the consecutive section of first-order Takagi-Sugeno models. The ANFIS structure consists of 5 layers. Figure 1 and a summary of the model are shown below.

The first layer (input nodes): The membership values that belong to each of the appropriate fuzzy sets are created using the membership function in each node of this layer.

$$\begin{aligned} O_{1,i} &= \mu_{A_i}(x); \text{ for } i=1,2 \\ O_{1,i} &= \mu_{B_{i-2}}(x); \text{ for } i=3,4 \end{aligned} \quad (1)$$

Where x and y are non-phase inputs to nodes i, Ai and Bi are language labels which are specified by appropriate membership functions μ_{A_i} and μ_{B_i} , respectively. Since the quadratic Gaussian function has high simulation accuracy, the quadratic Gaussian membership functions have been used in this study.

The second layer (Rule Nodes): In the second layer, the "and" (AND) and "or" (OR) operators are used to obtain the output. The O2,k outputs of this layer are the product of the degrees corresponding to the first layer.

$$O_{2,k} = \mu_{A_i}(x) + \mu_{B_j}(y) ; \quad k=1, \dots, 4 \quad (2)$$

$i=1,2; j=1,2$

The third layer (Medium Nodes): The main purpose of the third layer is to determine the weight ratio of the i-th to the weight of all the rules. As a result, wi is obtained as a normalized weight:

$$O_{3,i} = \bar{w}_i = \frac{w_i}{\sum_{k=1}^4 w_k}; \quad i = 1, \dots, 4 \quad (3)$$

The layer four (Result Nodes): The node function calculates the fourth layer of the i-th distribution law to the total output and is defined as follows:

$$O_{4,i} = \bar{w}_i f_i = \bar{w}_i (p_i + q_i + r_i); \quad i = 1, \dots, 4 \quad (4)$$

Where \bar{w}_i is the i-th node output from the previous layer {pi, qi, ri}(16). The coefficients of this combination are linear and are also the set parameters of the Takagi-Sugeno fuzzy model.

The fifth layer (Output Nodes): This single node calculates the total output by summing all the input signals. Therefore, in this layer, the results of each fuzzy rule are transformed into non-fuzzy outputs.²⁸

$$O_{5,i} = \bar{w}_i f_i = \frac{\sum_{i=1}^4 w_i f_i}{\sum_{i=1}^4 w_i} \quad (5)$$

This network is based on peer learning. Therefore, our goal is to train adaptive networks that are able to estimate the unknown functions of the training information and find the exact value for the above parameters.²⁹⁻³² The use of fuzzy logic provides the ability to estimate the likelihood of an unsafe and incident operation using fuzzy series.³³ Fuzzy logic has recently been proposed for modeling data and solving ambiguous properties. However, the main problem with fuzzy logic is that there is no kinematic process for designing a fuzzy controller. In other words, a neural network has the

ability to learn from the learning environment (input-output pairs) to arrange its structure, and to adapt its interaction in a manner.³⁴ To this end, professor Jung introduced the ANFIS model in 1993 which was able to combine the two methods mentioned above.³⁵ Given that the idea of predicting unsafe behavior or industrial events using fuzzy logic and neural network combinations has not been implemented so far; the idea is highly predictive in this study using qualitative data collected from cultural attitudes. In addition, the safety atmosphere is modeled by unsafe behavior with a neuro-fuzzy inference system.¹³

Methods

The present study is a descriptive cross-sectional study that was performed on 90 construction workers with minimum of 5 years of experience using sampling, interviewing and recording of unsafe behavior. Exclusion criteria include the elimination of accident and low work experience. The questionnaire of safety atmosphere and cultural attitudes was presented to 90 persons in the form of presentations and how they were completed. The distribution of safety atmosphere scores and cultural attitudes of workers was calculated based on a Likert 5-point range with a minimum score of 1 and a maximum of 5. To obtain the dimensions of safety atmosphere and cultural attitudes, the points of the questions were collected and their mean was calculated. Prior to this study, a baseline assessment was conducted to familiarize workers with the processes in the workplace, and then a list of unsafe behavior was performed at the study site. The important thing in conducting this study was that the workers did not understand what the observer was looking for because they could change their behavior if they were aware of the observer's purpose. Before conducting the pilot study, it was necessary to determine the time of the observation of the workers' behavior randomly and accurately.

In this study, a questionnaire presented by the UK Health and Safety Organization in 2001 was used to determine the safety atmosphere and its related dimensions. Many dimensions are known as components of a safe atmosphere. Questionnaire containing 37 items which consists of 8 dimensions of safety atmosphere including management commitment (dimension 1), worker knowledge (dimension 2), worker attitudes (dimension 3), worker participation (dimension 4), workplace safety (dimension 5), immediate readiness in workplace (dimension 6), product safety priority

(dimension 7) and risk aversion (dimension 8). The questionnaire presented is a comprehensive set of questions that can be used to assess the safety atmosphere and its related features. In our country, this questionnaire was validated with a content validity ratio of 78.5 and CVI value using the Lauche method of 0.82.³⁶ Cultural attitude questionnaire contains 25 items consisting of 4 dimensions including the dimension of masculinity-feminism (dimension 1), collectivism- individualism (dimension 2), ambiguity (dimension 3), and power distance (dimension 4). Validation of this questionnaire in Iran with Cronbach's alpha coefficient of reliability was 0.78.^{35, 37}

Sampling safety behaviors were used to assess unsafe behaviors.³⁸ In this study, practical unsafe behavior is outside the standard and has defined the limits of the system and can affect the level of safety of the system.³⁹ To this end, a list of unsafe behavior was prepared according to the list of unsafe behavior of the American Society of Safety Engineers (ANSI), the type and nature of the work, the rules of the review, the work instructions, and reports of factory accidents and existing cultural conditions.⁴⁰ It should be noted that the studied samples, time and day of observation were determined in a completely random way through Excel 2016 software. All observations were made in the morning shift from 8 a.m. to 4 p.m., and since each person's behavior could change at any moment from their previous moment, it was attempted that the time of each observation was as long as possible. It should be short and selected only to the extent that the observer is able to observe the action and determine whether it is safe or unsafe to the list.³⁸ In this study, the observation time was between 3 to 5 seconds.

The algorithm uses the Sugeno structure because it employs a combination of error propagation and minimum squares error training for the training process and the mean weight function for non-fuzzy.⁴¹

To design the optimal fuzzy neural network system, the continuous topology of the neural network was investigated through a continuous change of the number of layers and the number of hidden layer neurons. The default parameters that define membership functions were determined using the gradient method and the resulting parameters were determined using the least-squares method. The input data were trained and tested based on the parameters considered and then used to predict unsafe behavior. After training and testing, the error reached a steady state. Experimental were compared to evaluate the desired models from Explanation

Coefficient (R2), Root Mean Square Error (RMSE), Mean Absolute Error Magnitude (MAE), Standard Error Mean Square (MSE), Normalized Error Mean Square (NMSE) and Wilmot agreement index (d) have been used.⁴² The low RMSE value and the high R2 coefficient indicate acceptable accuracy of the model and its superiority over the other model. MAE, MSE, and NMSE each represent in a way the difference between observational and computational data, the lower these values, the more efficient the work will be.^{43, 44}

Results

The organizational characteristics of the study subjects are presented in Table 1. The mean age of the subjects was 35.56 years with a standard deviation of 8.1 and work experience of 12.37 years with a standard deviation of 7.2.

In this study, the relationship between safety atmosphere and cultural attitude with unsafe behavior (Model 1), safety atmosphere with unsafe behavior (Model 2), cultural attitude with unsafe behavior (Model 3) was investigated by the

neuro-fuzzy inference system. Then, the results of different input structures to the ANFIS model are evaluated by statistical parameters in Table 6. The structure of the ANFIS model was used in this study to illustrate the impact of safety atmosphere and cultural attitudes on unsafe behavior which is shown in Figure 4.

Table 2 presents the different input structures of the ANFIS model.

Figures 5 to 7 illustrate the distribution graphs of the observed data against the predicted data using the neuro-fuzzy model. In these graphs, the fitted regression line between the data is represented by the line and the regression line equation is shown in each graph.

Table 1. Personal and organizational characteristics

| job | Frequency (%) |
|-------------------|---------------|
| Assembly operator | 41 (45.6%) |
| Car Operator | 33 (36.7%) |
| worker | 7 (7.8%) |
| office Employee | 9 (10%) |

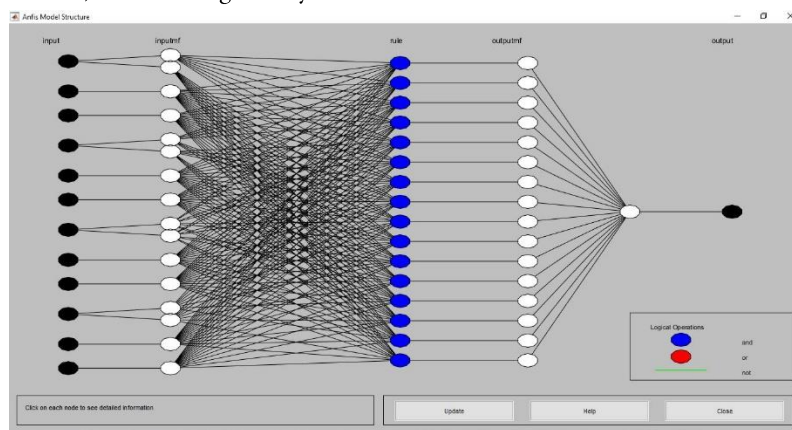

Figure 4. The structure of the ANFIS model used in this study

Table 2. Results of different input structures to the ANFIS model

| Model | Model inputs | Regression (R2)coefficient |
|-------|---|----------------------------|
| 1 | A ₍₁₎ , A ₍₂₎ , A ₍₃₎ , A ₍₄₎ , B ₍₁₎ , B ₍₂₎ , B ₍₃₎ , B ₍₄₎ , B ₍₅₎ , B ₍₆₎ , B ₍₇₎ , B ₍₈₎ | 0.9453 |
| 2 | B ₍₁₎ , B ₍₂₎ , B ₍₃₎ , B ₍₄₎ , B ₍₅₎ , B ₍₆₎ , B ₍₇₎ , B ₍₈₎ | 0.9337 |
| 3 | A ₍₁₎ , A ₍₂₎ , A ₍₃₎ , A ₍₄₎ | 0.9234 |

Table 3. Statistical parameters of ANFIS model accuracy in predicting unsafe behavior

| Model | R2 | NMSE | MSE | D | MAE | RMSE |
|-------|--------|--------|---------|--------|--------|--------|
| 1 | 0.9453 | 0.0547 | 16.3889 | 0.9858 | 0.7778 | 4.0483 |
| 2 | 0.9337 | 0.0665 | 19.8962 | 0.9823 | 1.3852 | 4.4605 |
| 3 | 0.9234 | 0.0767 | 22.9699 | 0.9795 | 1.8115 | 4.7927 |

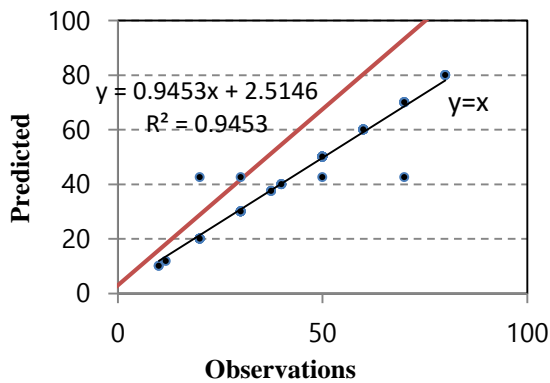

Figure 5. Relationship between safety atmosphere and cultural attitude with unsafe behavior (Model 1)

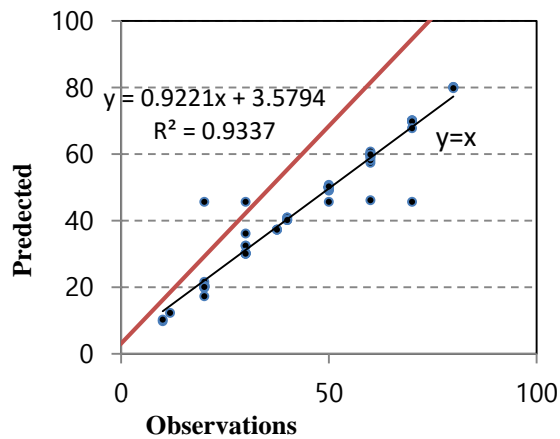

Figure 6. Relationship between safety atmosphere and unsafe behavior (Model 2)

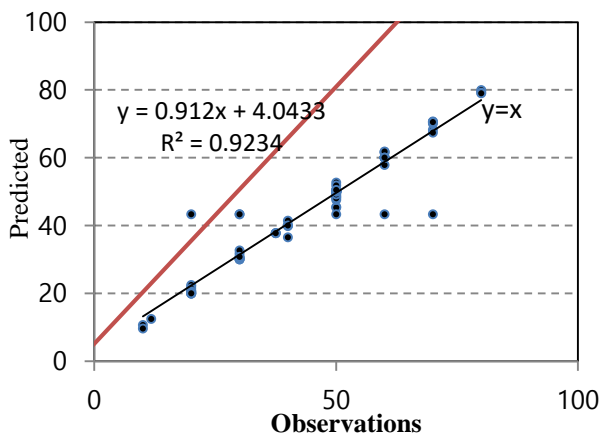

Figure 7. Relationship between cultural attitudes with unsafe behavior of Model 3

Discussion

The neuro-fuzzy model created indicates that it is essential that modeling of unsafe behavior can be used as a valid and appropriate approach to accident prevention and prevention in addition to the interpretation of this model and the algorithm that can be expressed based on this analytical approach. Using safety-related scores and cultural attitudes, the unsafe behavior in the construction industry can be predicted. Studies have shown that unsafe behavior and industrial accidents are influenced by various factors.⁴⁵ Because of the complexity of these industries (2), it is challenging to analyze unsafe behavior by conventional and conventional analytical methods, and the results are insufficient.⁴⁶ The purpose of this study was to investigate the safety atmosphere and cultural attitudes to predict the number of unsafe behavior in a construction company's workshops. Analytical modeling using neuro-fuzzy logic showed that the parameters related to safety atmosphere and cultural attitudes were identified as essential factors in the occurrence of unsafe behavior in the construction industry. Neuro-fuzzy modeling results indicated that among 12 analyzed indices that were selected as model inputs, the parameters related to the safety atmosphere had the most significant role in the occurrence of unsafe behavior ($R = 0.93$). This model alone can be used to predict unsafe behavior in industries. Mohammad fam et al. (2016) found that using neural networks can be a useful tool for analyzing and predicting the severity of accidents in the industries.⁴⁶ The results of the different input structures to the model are presented in Table 2. As it can be seen in Models 2 and 3 (Figures 6 and 7), it can be concluded that unsafe behavior is closely related to the safety atmosphere and cultural attitudes considering each the criteria.

The statistics presented in Table 3, regression coefficients for Models 2 and 3 were 0.9337 and 0.9234, respectively which had an acceptable performance for assessing unsafe behavior. These results are consistent with various studies on the safety atmosphere and cultural attitudes.^{16, 46} However, Model 2 yields better results comparing to Model 3. Furthermore, according to Table 3, it was observed that Model 1 (Figure. 5), which combines both safety atmosphere and cultural attitude parameters in estimating unsafe behavior, achieved better results with a

regression coefficient of 0.9903 indicating that the direct impact of both parameters is on the number of unsafe behavior simultaneously. Given that the RMSE indicates low accuracy of the model, the mean squared error in Model 1 (4.04) is lower than in Models 2 and 3, so it seems to be predictive. The extent of unsafe behavior and industrial accidents is more accurate using safety atmosphere questionnaires and modeling cultural attitudes. In this study, the MAE criterion was used to evaluate three models. If the MAE is zero or close to zero, the method used is highly accurate.

According to Table 3, it was observed that the MAE for model 1 is lower than models 2 and 3 indicating that the simultaneous use of safety atmosphere parameters and cultural attitudes for modeling are more accurate. A study done by Mearns showed that simultaneous use of safety atmosphere parameters and cultural attitudes can be useful for investigating work-related accidents and absences.¹⁴ In this regard, according to Table 2, as the number of inputs to the model increases, the coefficient of explanation (R²) increases, which is consistent with similar results.⁴⁶ As noted in this study, only a safety atmosphere and cultural attitudes were used to predict the unsafe behavior. However, other factors may be affected in creating unsafe behavior that, using other factors influencing unsafe behaviors model inputs, the accuracy of the estimates can be increased, and more useful information can be provided to industry safety management.¹³

Conclusion

The findings of this study and other studies indicate that it is essential that unsafe behavior can be influenced by the safety atmosphere and cultural attitudes.⁸ The modeling results have shown that using a neuro-fuzzy network can be a suitable approach to predict the contributing factors of the unsafe behavior and the industrial events. In addition to the interpretation of this model and the obtained algorithm, it can be stated that, based on this analytical model, having unsafe and cultural attitudes can predict unsafe behavior in the construction industry. Studies done in recent years have emphasized that the nature of the organization has an impact on the safety culture, cultural attitudes, and incidence rates. Understanding the safety atmosphere, cultural attitude and its related dimensions by the organization reduce the incidence rate of the accidents. In organizations where safety atmosphere and cultural

attitudes have been accepted as a subset of safety culture; safety behavior among employees have been reinforced, and there has been a positive and meaningful relationship between reducing accidents and safety behaviors.⁸ Since the regression coefficient of model 1 is higher than models 2 and 3, and the mean squared error of model 1 is lower than models 2 and 3, it is recommended to use factors related to safety atmosphere and cultural attitudes to model and predict unsafe behavior.

Acknowledgments

The authors would like to express their special gratitude to all the participants of the study. The study was approved by the respective university ethics' committee (IR.TUMS.SPH.REC.1396.3976).

References

- Ghajari A, Lotfali E, Azari M, Fateh R, Kalantary S. Fungal airborne contamination as a serious threat for respiratory infection in the hematology ward. *Tanaffos*. 2015;14(4):257-61.
- Hinze JW, Teizer J. Visibility-related fatalities related to construction equipment. *Safety science*. 2011;49(5):709-18.
- Jafari M, Gharari M, Ghafari M, Omidi L, Kalantari S, Asadolah-Fardi GR. The influence of safety training on safety climate factors in a construction site. *International journal of occupational hygiene*. 2014;6(2):81-7.
- Jafari MJ, Gharari M, Kalantari S, Omidi L, Ghaffari M, Asadolah-Fardi GR. The influence of safety training on improvement in safety climate in construction sites of a firm. *Safety promotion and injury prevention*. 2014;2(4):257-64. [Persian]
- Mohammad Fam I, Zokaei H, Simaei N. Epidemiological evaluation of fatal occupational accidents and estimation of related human costs in Tehran. *Zahedan university of medical sciences and health services*. 2007;8(4):299-307. [Persian]
- Kaila H. Behaviour based safety in organizations: A practical guide: IK International Pvt Ltd; 2008.
- Vosoughi S, Oostakhan M. An Empirical investigation of safety climate in emergency medical technicians in Iran. *International journal of occupational hygiene*. 2011;3(2):70-5.
- Jafari MJ, Gharari M, Ghafari M, Omidi L, Asadolah-Fardi GR. Investigating the safety atmosphere and its associated factors in a construction firm in 2011. *Health in the Field*. 2014;2(3):1-7. [Persian]
- Sadullah Ö, Kanten S. A research on the effect of organizational safety climate upon the safe behaviors. *Ege academic review*. 2009;9(3):923-32.
- Omidi L, Zare S, Moradi Rad R, Meshkani M, Kalantary S. Effects of shift work on health and satisfaction of workers in the mining industry. *International journal of occupational hygiene*. 2017;9(1):21-5.
- Neal A, Griffin MA, Hart PM. The impact of organizational climate on safety climate and individual behavior. *Safety science*.

- 2000;34(1-3):99-109.
12. Jafari MJ, Gharari M, Ghafari M, Omidi L, Kalantari S, Asadolah-Fardi GR. The influence of safety training on safety climate factors in a construction site. *International journal of occupational hygiene*. 2014;6(2):81-7.
 13. Hofstede G, Bond MH. Hofstede's culture dimensions: An independent validation using Rokeach's value survey. *Cross-cultural psychology*. 1984;15(4):417-33.
 14. Mearns K, Rundmo T, Flin R, Gordon R, Fleming M. Evaluation of psychosocial and organizational factors in offshore safety: a comparative study. *Risk research*. 2004;7(5):545-61.
 15. Rezaei MS, Golbabaei F, Behzadi MH. Assessing the healthcare Workers' Knowledge, Attitude, and Practice toward Health, Safety, and Environment in an Educational Hospital Affiliated by Iran University of Medical Sciences (2012-2013). *Environmental science and technology*. 2017;19(4):347-55. [Persian]
 16. Mearns K, Yule S. The role of national culture in determining safety performance: Challenges for the global oil and gas industry. *Safety science*. 2009;47(6):777-85.
 17. Jakhar SK, Barua MK. An integrated model of supply chain performance evaluation and decision-making using structural equation modelling and fuzzy AHP. *Production planning & control*. 2014;25(11):938-57.
 18. Gyekye SA, Salminen S, Ojajarvi A. A theoretical model to ascertain determinates of occupational accidents among Ghanaian industrial workers. *International journal of industrial ergonomics*. 2012;42(2):233-40.
 19. Pourbabaki R, Karimi A, Yazdanirad S, JJoHitF. Modeling the consequences and analyzing the dangers of carbon disulfide emissions using ALOHA software in an oil refinery. *Health in the Field*. 2018;6(3):24199.
 20. Peters ME. New federal transportation safety initiative: implications for the states. *Spectrum: the Journal of State Government*. 2004;77(1):25-7.
 21. Wang L, Rajapakse JC, Fukushima K, Lee S-Y, Yao X. gfh International Conference on Neural Information Processing. ICON. 2002;1:02.
 22. Al-Mahadin A, Bouzlama F, editors. Neuro-fuzzy techniques for the identification of aircraft wake vortex encounters. *Advances in Science and Engineering Technology International Conferences (ASET)*, 2018;2018: IEEE.
 23. Kalantary S, Jahani A, Pourbabaki R, Beigzadeh Z. Application of ANN modeling techniques in the prediction of the diameter of PCL/gelatin nanofibers in environmental and medical studies. *RSC advances* 2019;9(43):24858-74.
 24. Jahani A. Forest landscape aesthetic quality model (FLAQM): a comparative study on landscape modelling using regression analysis and artificial neural networks. *Forest science*. 2019;65(2):61-9.
 25. Renjith VR, Madhu G, Nayagam VLG, Bhasi AB. Two-dimensional fuzzy fault tree analysis for chlorine release from a chlor-alkali industry using expert elicitation. *Hazardous materials*. 2010;183(1-3):103-10.
 26. Horikawa S. A fuzzy controller using a neural network and its capability to learn expert's control rules. *Proc of Int'l Conf on Fuzzy Logic and Neural Networks (IJZUKA'90)*; 1990.
 27. Athanassopoulos AD, Curram SP. A comparison of data envelopment analysis and artificial neural networks as tools for assessing the efficiency of decision making units. *Journal of the operational research society*. 1996;47(8):1000-16.
 28. Akbarifard S, Sharifi MR, Qaderi K. Data on Optimization of the Karun-4 Hydropower Reservoir Operation Using Evolutionary Algorithms. *Data in Brief*. 2020;29:105048.
 29. Buragohain M, Mahanta C. A novel approach for ANFIS modelling based on full factorial design. *Applied soft computing*. 2008;8(1):609-25.
 30. Rutkowski L, Cpałka K. Flexible neuro-fuzzy systems. *IEEE transactions on neural networks*. 2003;14(3):554-74.
 31. Sulaiman G, Younes MK, Al-Dulaimi GA. Modelling of CO₂ and NO_x on signalize roundabout using Modified Adaptive Neural Fuzzy Inference System (ANFIS) model. *Environmental engineering reserch*. 2018.
 32. Jahani A, Makhdom M, Fegghi J, Etemad V. Landscape quality appraisal from look outs for ecotourism land use (Case Study: Patom District of Kheyrod Forest). *Environmental researches*. 2011;2(3):13-20. [Persian]
 33. Suparta W, Alhasa KM. *Modeling of tropospheric delays using ANFIS*: Springer; 2016.
 34. Jahani A. Modeling of forest canopy density confusion in environmental assessment using artificial neural network. *Iranian journal of forest and poplar research*. 2016;24(2):310-21.
 35. Esmaeili GH, Akhond AA, Zarei H, Taghian M. Evaluation of the ability of adaptive neuro-fuzzy interface system, artificial neural network and regression to regional flood analysis. *Water and soil conservation*. 2017;24(3):149-66.
 36. Jafari MJ, Sadighzadeh A, Sarsangi v, Zaeri F, Zarei E. Development and Psychometrics of " Safety Climate Assessment Questionnaire". *Safety Promotion and Injury Prevention*. 2013;1(3):123-33. [Persian]
 37. Blodgett JG, Bakir A, Rose GM. A test of the validity of Hofstede's cultural framework. *Consumer marketing*. 2008;25(6): 339-49.
 38. Mohammadfam I, Zamanparvar A. The Evaluation of Workers Unsafe Acts in Godazan Foundry in 2000. *Avicenna journal of clinical medicine (scientific journal of hamadan university of medical sciences and health services)*. 2002;9(1):51-6. [Persian]
 39. Lund J, Aarø LE. Accident prevention. Presentation of a model placing emphasis on human, structural and cultural factors. *Safety science*. 2004;42(4):271-324.
 40. Guldenmund FW. The nature of safety culture: a review of theory and research. *Safety science*. 2000;34(1-3):215-57.
 41. S Akbarifard, Akhoondali A. Simulation of sea wave height using metaheuristic algorithms in Chabahar. *Iranian Journal of Marine Technology*. 2017;4(3):73-84.
 42. Bahraminejad M, Rayegani B, Jahani A, Nezami B. Proposing an early-warning system for optimal management of protected areas (Case study: Darmiyan protected area, Eastern Iran). *Nature conservation* 2018;46:79-88.
 43. Samiei S, Alefi M, Alaei Z, Pourbabaki R. Risk Factors of Low Back Pain Using Adaptive Neuro-Fuzzy. *Archives of occupational health*. 2019;3(2):339-45.
 44. Akbarifard S, Radmanesh F. Predicting sea wave height using Symbiotic Organisms Search (SOS) algorithm. *Ocean Engineering*.

2018;167:348-56.

45. Mohammadfam I, Soltanzadeh A, Moghimbeigi A, Akbarzadeh M. Modeling of individual and organizational factors affecting traumatic occupational injuries based on the structural equation modeling: a case study in large construction industries. *Archives of trauma*

research. 2016;5(3):e33595.

46. Soltanzadeh A, Mohammadfam I, Mahmoudi S, Savareh BA, Arani AM. Analysis and forecasting the severity of construction accidents using artificial neural network. *Safety Promotion and injury prevention*. 2016;4(3):185-92. [Persian]