

# Introduction of a Simple Chamber for the Production and Simulation of Airborne Pollutants for Laboratory Use

Hossein Fallah<sup>1\*</sup>, Abolfazl Barkhordari<sup>2</sup>, Gholamhossein Halvani<sup>3</sup>, Rajabali Hokmabadi<sup>4</sup>

<sup>1</sup> PhD Student of Ergonomics, Department of Occupational Health and Ergonomics, Faculty of Health, Tabriz University of Medical Sciences, Tabriz, Iran<sup>2</sup> PhD, Department of Occupational Health, Faculty of Health, Shahid Sadoughi University of Medical Sciences, Yazd, Iran<sup>3</sup> MSc, Department of Ergonomics, Faculty of Health, Shahid Sadoughi University of Medical Sciences, Yazd, Iran<sup>4</sup> MSc, Department of Occupational Health Engineering, Health School, North Khorasan University of Medical Sciences, Bojnurd\* Corresponding Author: Fallah Hossein, Email: Fallah\_hossein@yahoo.com, Tel: +98-0913-2572540

## Abstract

**Background:** Designing training aids for students to increase their practical capability and skills is done by using modern educational methods. The aim of this study was to design a simulator of airborne pollutants for measuring gases, vapors and particles in the lab for student training. **Methods:** The present study investigated different systems based on reviewing the literature of conducted research studies around the world. Then, designing the simulator system of the airborne pollutants was carried out after studying the capabilities of available systems, considering the viewpoints of experts and focusing on the aims of the study. **Results:** The designed chamber consisted of a main component which, in addition to some complexes such as the blowing system, the evacuation funnel, the warming chamber, and control box, made the production and simulation of the particle and gaseous pollutants feasible in different atmospheric conditions. **Conclusions:** The production and simulation of airborne pollutants in an experimental chamber under controlled conditions can facilitate the accomplishment of different assessments on pollutants. The designed device benefits both having a simple yet creative fabricated system and low manufacturing costs. Therefore, it can be used readily as a suitable device for extensive research on pollutants in the educational and research centers.

**Key words:** Simulation chamber; Airborne pollutants; Sampling; Laboratory

## Introduction

Currently, the most significant method for the assessment of workers' exposure to air pollutants are the air sampling procedures and biological monitoring<sup>1,2</sup> However, the assessed exposures via these methods may not be applied to

other different environments and conditions. Therefore, other methods of assessing exposure in work environments should be used instead of monitoring including modeling methods.<sup>1,3,4</sup> Despite the availability of numerous chemical exposure

**Citation:** Fallah H, Barkhordari A, Halvani Gh, Hokmabadi R. **Introduction of a Simple Chamber for the Production and Simulation of Airborne Pollutants for Laboratory Use.** Archives of Occupational Health. 2018; 2(3): 156-63.

**Article History:** Received: 26 November 2018; Revised: 9 April 2018; Accepted: 9 June 2018

**Copyright:** ©2017 The Author(s); Published by Shahid Sadoughi University of Medical Sciences. This is an open-access article distributed under the terms of the Creative Commons Attribution License (<https://creativecommons.org/licenses/by/4.0/>), which permits unrestricted use, distribution, and reproduction in any medium, provided the original work is properly cited.

assessment methods,<sup>5,6</sup> none of them can be considered as the best standard by itself due to some measurement errors.<sup>7,8</sup> Regarding these limitations, the application of these production and simulation systems in the laboratory can facilitate the research on pollutants in the workplaces. Simulation, which is in fact an imitation of a real system or process, can be used in the analysis, comparison, and improvement of complicated systems. Production, collection, and measurement of aerosols in a controlled laboratory range can function as a significant device in determining the potential spread of particles from different sources. The particles produced on the laboratory scale can resemble the environmental pollutants regarding size, form, composition or, at least, other components, without being affected by other pollutants.<sup>9,10</sup>

Experimental dust production is done for many purposes as studying the control processes of factories, inhalational toxicology, environmental health, research epidemiology, and pharmacological issues. Today, a wide range of laboratory and commercial instruments are used to produce aerosols and there are several distinct classes of dust producers including floating devices, particle falling chambers, cylinder-shaped containers, and revolving tubes. Furthermore, various types of production chambers for re-suspension and sampling of particles<sup>10</sup> biological applications,<sup>11</sup> wind erosion and unstable particles<sup>12</sup> have been designed and used. Dust measurement tools are also used for other goals such as the simulation of the dust in workplaces,<sup>13</sup> controlling processes,<sup>14</sup> drug industry<sup>15,16</sup> exposure of laboratory animals to dust particles for research purposes,<sup>17,18</sup> sample preparation for chemical analysis,<sup>19</sup> study of echo physiological effects on the amount of accumulation of particles on leaves,<sup>20</sup> simulation of dust infiltration into buildings,<sup>21,22</sup> and predicting the accumulation and spread of particles on other planets or extra-atmospheric space.<sup>23</sup> Furthermore, simulation chambers have been used

for research purposes in several studies as the following.

Chung et al.(2000) used a chamber to assess particles and formaldehyde vapors when machining MDF plates.<sup>24</sup> Another study (2006) in California used a cheap double-purpose chamber to investigate gases as well as particles.<sup>25</sup> This device was also used to evaluate the biological factors of dust measurement in houses.<sup>26</sup> Another application of the chambers was the assessment of particle explode ability. Mention can be made of the 20-L Siwek chamber used extensively for this goal.<sup>27</sup> Lee et al. (2005) investigated the effect of temperature differences on the scattering of airborne pollutants in a chamber fabricated for this purpose.<sup>1</sup> The study by Page (2000) investigated the correlation between electrostatic properties and moisture in coal dust using a chamber designed for this purpose.<sup>28</sup> Furthermore, another study conducted on coal dust for laboratory tests used a chamber called Marple.<sup>29</sup> The study by Randal (2010) used a chamber to assess agricultural dust.<sup>30</sup> Lingjuan et al. (2003) investigated the effectiveness of some samplers using a special chamber.<sup>31</sup> Another study (2002) on the simulation of Mars dust particles in low speeds used a chamber called Merrison.<sup>32</sup> Moreover, Urbain et al. (1996) investigated the effect of chronic exposure of swine to dust and endotoxins using a simulation chamber.<sup>33</sup> One application of experimental chambers is testing different fire detectors and gas leakage detectors, e.g., the study by Charles (2009) which assessed smoke detectors in mines using an experimental simulation chamber.<sup>34</sup> The study by Kenneth et al. (2007) investigated the post-explosion events of mines using an experimental chamber named Fike.<sup>35</sup> Another study by Afshari et al. (2005) focused on the investigation of the sources of work environment dust particles as cigarette smoking, deodorant sprays, burning candles, vacuum cleaners, meat toasting by electric stoves, ironing, and gas stoves using a chamber.<sup>36</sup>

Approximately, all of the simulation chambers used in above-mentioned studies had experimental usage,

and due to their limitations, they are not used for educational purposes. Consequently, the purpose of the present study was to introduce a simple yet creative designed chamber for the simulation of airborne pollutants in laboratory conditions. The specific properties of this device make it suitable for the production of particle pollutants, gas, vapor, and varying atmospheric conditions within the chamber. It is hoped that these capabilities make the production and sampling of various pollutants possible in laboratory conditions.

### Methods

Reviewing the related literature, it was found that a wide range of simulation chambers had been designed and fabricated for different purposes. However, the main point was that each chamber was designed and applied for just one specific research purpose and multi-purpose designs were both complex and expensive. Therefore, the researcher decided to design such a system with high complex capabilities and low costs. The aim of this study was to design and produce training aids for students to increase their practical capability and skills using modern educational methods. Therefore, In this study, the features and capabilities of the built-in device were described. As well as the similar studies published in these subjects, the statistical methodology of research (Sampling, Sample size, Analysis method) was not required.

Some investigation revealed that the newly devised system should be capable of both production of particle pollutants, gases, vapors, and various work environment conditions, and the possibility of simulation of various conditions as well as simultaneous simulation of pollutants. Based on the defined capabilities of the device, the determined structure and equipment for this

purpose were suggested. Then, various designs were studied and their advantages and disadvantages were determined. After that, the best design of the system was offered by considering parameters such as simplicity, cost-effectiveness, portability, and sensitivity. Ultimately, the general design of the chamber was decided by considering ergonomic principles, and the location of parts was determined.

Afterward, the details provided on the map and the pre-model was made using other materials and after ensuring the proper operation of the prototype, the main model was built using original materials. In the end, all parts and components of prototype were tested and deficiencies and defects were identified and removed. Since the main goal of building this system was using it for train in gap plications; therefore, its performance was reviewed and approved by several occupational health masters. Since one of the potentiality of device was releasing of gases and vapors in the inner chamber; thus, a little amount of benzene placed in a heating chamber and released into the main chamber by passing air volume and temperature. Then, the uniformization was performed in education. Subsequently, benzene quantity was measured using detector tubes. This procedure was repeated several times with the same conditions and after each test, the chamber was thoroughly washed and the measured values were compared.

### Results

The simulation chamber consisted of a main component integrated with other parts as the air blowing system, materials evacuation funnel, the warming chamber, and the control box. This makes the production and simulation of gaseous and particle pollutants in various air conditions Figure 1.



**Figure 1.** Photograph of airborne pollutant simulation chamber

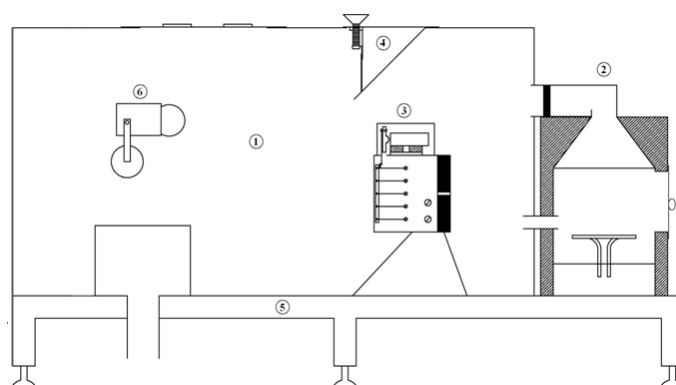

**Figure 2:** Schematic diagram of airborne pollutant simulation chamber  
(1. Main chamber, 2. Warming chamber, 3. Blowing system, 4. Evacuation funnel, 5. Platform, 6. Filament lamp)

The main chamber was a rectangle cube with  $40 \times 40 \times 80$  cm<sup>2</sup> dimensions and could be attached to the input/output ports of the warming chamber via the lateral wall.

The warming chamber is located adjacent to the main chamber. It has a structure similar to an oven. It has both the capability of regulating its internal temperature and controlling the volume of the passing air into the warming chamber. This multi-purpose chamber is capable of controlling temperature, moisture, vaporization of solvents, and their transmission into the main chamber Figure 2.

The blowing system is another component of this device located within the main chamber. It includes a fan with adjustable speed and air-directing blades with adjustable speed. The function of this part is the production of air current at different speeds and also the production of directed or disturbed current in the main chamber Figure 3. The evacuation

funnel is another component of this chamber which enables us of producing particle pollutants via the falling mechanism. This is in fact a slopped chamber with an adjustable slot. It is located in the upper plane of the main chamber and above the blowing system and makes the production of particle pollutants possible Figure 4. The control box contains electric circuits and controls Figure 3; therefore, the equipment of the system and parameters as the main fan speed, the amount of the movement of air-directing blades, the amount of warmth produced in the chamber, the rate of the volume of the passing air in the warming chamber, and also the rate of radiating warmth can be controlled parallels and simultaneously with controls located on it. In this way, many conditions can be produced and simulated even for just one specific pollutant in the main chamber.

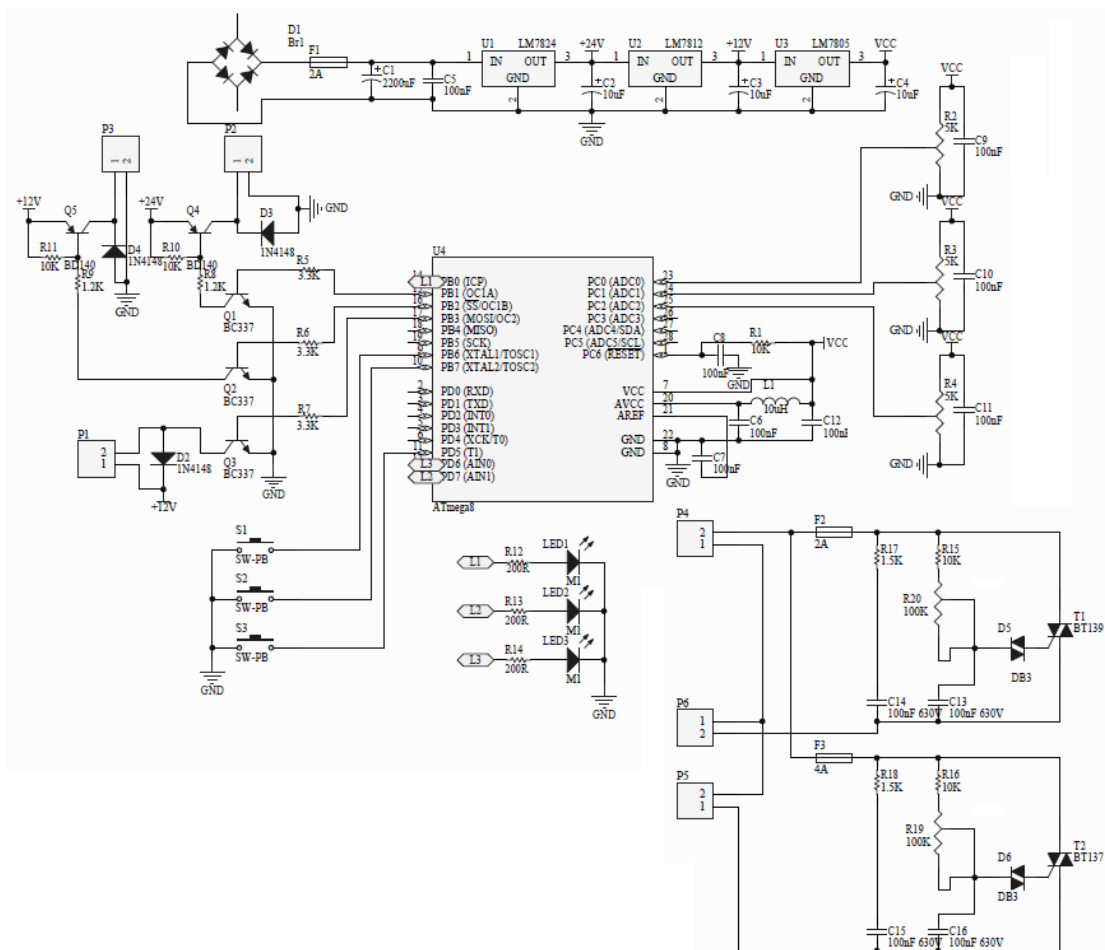

Figure 3. Schematic design of electric circuit of airborne pollutant simulation chamber

## Benzene

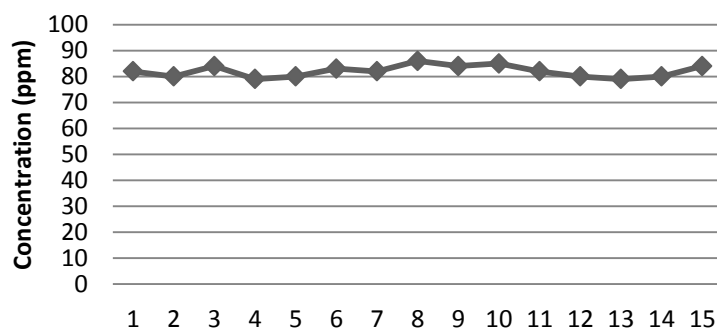

Figure 4. Benzene concentrations measured during 15 repeated tests in same conditions

The main chamber and all the peripheral components are located on a platform with adjustable legs Figure 5.

Using the above components, the production and simulation of gaseous and particle pollutants and

various air conditions in the main frame become possible which will be explained as the following:

1-Production of particle pollutants: To do so, the powdered materials are poured into the evacuation funnel. While the fan of the air blowing system is

circulating, the amount of falling of materials can be adjusted by turning the upper control of the funnel. In so doing, the falling powdered materials are exposed to air current and scattered in the main chamber space.

2-Production of pollutants in the gaseous and vapor forms: To release gases and vapors in the main chamber, a chemical or solvent should be placed in the warming chamber. The pollutants can be scattered in the main chamber space by changing the warming chamber temperature and controlling the amount of air passage in the chamber.

3-Production of various air conditions: Regarding the adjustability of temperature and passage of air in the warming chamber, the amount of temperature and moisture of the main chamber can be readily adjusted and an air current with different speeds can be produced in the main chamber with the air blowing system. Furthermore, directed and disturbed air current may be produced in the main chamber by adjusting the amount of movement of blades in front of the fan. Moreover, radiating heat with adjustable intensity may be produced by the filament lamp located in the wall of the main chamber Figure 2, 6. It should be mentioned that these capabilities can be used parallels; therefore, various conditions may be simulated.

The results of the benzene emissions assessment in the chamber showed that benzene amounts measure dafter each experiment were nearly similar, as well as, the mean benzene concentrations measured after 15 repeated tests in the same conditions (at all stages of measurement, volume of benzene was 1cc and the temperature and air flow velocity conditions were the same and equal to laboratory conditions)was 81.86 ppm Figure 4.

## Discussion

Production and simulation of airborne pollutants in a laboratory chamber can create controlled conditions and make the various assessments of

pollutants possible. Due to some complex risks at workplaces, the use of suitable instruments for assessing exposure to air pollutants is crucial.<sup>37</sup> Regarding the problems and limitations of the educational setting and research, the airborne pollutant simulator can be applied as a useful device.

This system has the capability of producing and simulating the gaseous, particle, and vapor pollutants, and various air conditions in the experimental setting of laboratory. It can be used for different methods of assessment of exposure to gases, vapors, and aerosols. The methods are currently used for the assessment of exposure to gases and vapors include: direct reading devices, detector tubes, complete air samplers, bubblers, and solid absorbent samplers. Moreover, the direct reading devices, impingers, filters, and size-selective samplers can be used for assessing exposure to aerosols.<sup>38</sup> This chamber can be easily used to evaluate the pollutants using each of the above-mentioned methods; therefore, it can have a wide range of educational and research applications. The fabrication of this device is an invention and there is no similar one. No reference is made to a device with similar capability, form, size, etc. in the literature.

## Conclusion

Due to the fact that simplicity and low cost are among the important factors for the selection and application of educational technology, and since this system enjoys a simple structure and creative design for the production and simulation of the particle, gaseous, and vapor pollutants, and is cost-effective; therefore, it is advised as a suitable tool for using in educational settings. Regarding the point that the main purpose of the fabrication of this device is its use in the educational settings, complex components are not used in it as far as possible. However, it enjoys the merit that other components may be added to it to increase its capacity and capability.



## Conflict of interest

The authors declare no conflict of interests.

## Acknowledgment

The Authors appreciate all of the workers who took part in this study.

## References

- Lee E, Feigley CE, Khan JA, Hussey JR. The effect of temperature differences on the distribution of an airborne contaminant in an experimental room. *The annals of occupational hygiene*. 2006;50(5):527-37.
- Burstyn I, Teschke K. Studying the determinants of exposure: a review of methods. *American industrial hygiene association journal*. 1999;60(1):57-72.
- Nicas M. Estimating exposure intensity in an imperfectly mixed room. *American industrial hygiene association journal*. 1996;57(6):542-50.
- Keil CB. A tiered approach to deterministic models for indoor air exposures. *Applied occupational and environmental hygiene*. 2000;15(1):145-51.
- Nieuwenhuijsen MJ. *Exposure assessment in occupational & environmental epidemiology*: us: Oxford University Press; 2015.
- Teschke K, Marion SA, Jin A, Fenske RA, van Netten C. Strategies for determining occupational exposures in risk assessments: a review and a proposal for assessing fungicide exposures in the lumber industry. *American industrial hygiene association*. 1994;55(5):443-9.
- Wacholder S, Armstrong B, Hartge P. Validation studies using an alloyed gold standard. *American journal of epidemiology*. 1993;137(11):1251-8.
- Tielemans E, Marquart H, De Cock J, Groenewold M, Van Hemmen J. A proposal for reevaluation of exposure data. *The Annals of Occupational Hygiene*. 2002;46(3):287-97.
- Marple VA, Liu BYH, Rubow KL. A dust generator for laboratory use. *American industrial hygiene association*. 1978;39(1):26-32.
- Kaya E, Hogg R, Mutmanský JM. Evaluation of procedures for production of dust samples for biomedical research. *Applied occupational and environmental hygiene*. 1996;11(7):745-50.
- Willeke K. Generation of aerosols and facilities for exposure experiments. *Symposium on aerosol generation and exposure facilities*. Honolulu, Hawaii (USA). Ann Arbor Science; 1980.
- Cowherd C, Grelinger MA. The appropriateness of a dustiness test chamber for representation of natural suspension phenomena. *PM10 standards and nontraditional particulate source controls*. Air & Waste Management Association, Pittsburgh, PA. 1992;346-56.
- Dahmann D. Ein Verfahren zur wirklichkeitsnahen bestimmung der staubungsneigung von schuttgutern. *Gefahrstoffe Reinhaltung der Luft*. 1997;57:503-7.
- Gill TE, Zobeck TM, Stout JE. Technologies for laboratory generation of dust from geological materials. *Hazardous materials*. 2006;132(1):1-13.
- Timsina MP, Martin GP, Marriott C, Ganderton D, Yianneskis M. Drug delivery to the respiratory tract using dry powder inhalers. *International journal of pharmaceutics*. 1994;101(1-2):1-13.
- Concessio NM, Jager-Waldau R, Hickey AJ. Aerosol delivery from an active emission multi-single dose dry powder inhaler. *Particulate science and technology*. 1997;15(1):51-63.
- Muhle H, Bellmann B, Creutzenberg O, Heinrich U, Ketkar M, Mermelstein R. Dust overloading of lungs after exposure of rats to particles of low solubility: comparative studies. *Aerosol science*. 1990;21(3):374-7.
- Janssen YM, Marsh JP, Absher MP, Hemenway D, Vacek PM, Leslie KO, et al. Expression of antioxidant enzymes in rat lungs after inhalation of asbestos or silica. *Biological chemistry*. 1992;267(15):10625-30.
- Morales JR, Dinator MI, Llona F, Saavedra J, Falabella F. Sample preparation of archaeological materials for PIXE analysis. *Radioanalytical and nuclear chemistry*. 1994;187(1):79-89.
- Hirano T, Kiyota M, Aiga I. Physical effects of dust on leaf physiology of cucumber and kidney bean plants. *Environmental pollution*. 1995;89(3):255-61.
- Lewis S. Solid particle penetration into enclosures. *Hazardous materials*. 1995;43(3):195-216.
- Chen YC, Barber EM, Zhang Y, Besant RW, Sokhansanj S. Methods to measure dust production and deposition rates in buildings. *Agricultural engineering research*. 1999;72(4):329-40.
- Fonda M, Petach M, Rogers CF, Huntington J, Stratton D, Nishioka K, et al. Resuspension of particles by aerodynamic deagglomeration. *Aerosol science and technology* 1999;30(6):509-29.
- Chung KYK, Cuthbert RJ, Revell GS, Wassel SG, Summers N. A study on dust emission, particle size distribution and formaldehyde concentration during machining of medium density fibreboard. *The Annals of occupational hygiene*. 2000;44(6):455-66.
- Edwards R, Smith KR, Kirby B, Allen T, Litton CD, Hering S. An inexpensive dual-chamber particle monitor: laboratory characterization. *The Air & Waste Management Association*. 2006;56(6):789-99.
- Mahakittikun V, Komoltri C, Nochot H, Insung A, Soonthornchareonnon N, Wongkamchai S, et al. Comparison of Siriraj chamber and other apparatus for restraining house dust mites. *Trop med parasitol*. 2003;26:93-7.
- Kalejaiye O, Amyotte PR, Pegg MJ, Cashdollar KL. Effectiveness of dust dispersion in the 20-L Siwek chamber. *Loss prevention in the process industries*. 2010;23(1):46-59.
- Page SJ. Relationships between electrostatic charging characteristics, moisture content, and airborne dust generation for subbituminous and bituminous coals. *Aerosol science and technology*. 2000;32(4):249-67.
- Volkwein JC, Thimons ED. New tools to monitor personal exposure to respirable coalmine dust. *Proceedings of the Seventh International Mine Ventilation Congress*; 2001. P:143-50.
- Southarda RJ. Sources, characteristics, and management of agricultural dust, San Joaquin Valley, California, USA. [POSTER] at *Proceedings of the 19th World Congress of Soil Science*. 2010 Aug 1-6, Brisbane, Australia. Brisbane, Australia; 2010: 190-2.
- Wang L, Wanjura JD, Parnell CB, Lacey RE, Shaw BW. Performance characteristics of low-volume PM10 inlet and TEOM continuous PM sampler. *Las Vegas ,Nevada, USA: ASAE*; 2003: 27-30.

32. Merrison JP, Bertelsen P, Frandsen C, Gunnlaugsson P, Knudsen JM, Lunt S, et al. Simulation of the martian dust aerosol at low wind speeds. *Geophysical research: planets*. 2002;107(E12):5133.
33. Urbain B, Prouvost JF, Beerens D, Michel O, Nicks B, Ansay M, et al. Chronic exposure of pigs to airborne dust and endotoxins in an environmental chamber. *Veterinary research*. 1996;27(6):569-78.
34. Litton CD. Laboratory evaluation of smoke detectors for use in underground mines. *Fire safety journal*. 2009;44(3):387-93.
35. Cashdollar KL, Weiss ES, Montgomery TG, Going JE. Post-explosion observations of experimental mine and laboratory coal dust explosions. *Loss prevention in the process industries*. 2007;20(4-6):607-15.
36. Afshari A, Matson U, Ekberg LE. Characterization of indoor sources of fine and ultrafine particles: a study conducted in a full-scale chamber. *Indoor air*. 2005;15(2):141-50.[Persian]
37. Tait K. The workplace exposure assessment expert system (WORKSPERT). *American industrial hygiene association journal*. 1992;53(2):84-98.
38. Harper M. Assessing workplace chemical exposures: the role of exposure monitoring. *Environmental monitoring*. 2004;6(5):404-12.